

# ABOUT US

Since our inception, we have upheld a commitment to fostering creativity and pushing the boundaries of technological innovation with a pioneering ethos.

Throughout our journey, the Shimabun brand has garnered trust from customers both locally and internationally, establishing itself as a leading manufacturer specializing in grating, boasting extensive experience and a proven track record. Central to our mission is customer satisfaction, propelling us to continually advance our technological capabilities and manufacturing processes, thereby contributing to society through the delivery of exceptional products and services.

Our exceptional universal design products not only ensure the safety and security of our customers but also prioritize their comfort and convenience. By attentively listening to our customers' feedback, we have strengthened our operations in various aspects, including quality, productivity, and manufacturing technology, thereby enhancing our competitiveness in the market.

We are confident that by further improving our products and expanding our sales network, both domestically and internationally, we can significantly enhance the company's value. Our dedication to collaborating with society in pursuit of our objectives aims to elevate our corporate worth and contribute to the creation of a prosperous community.

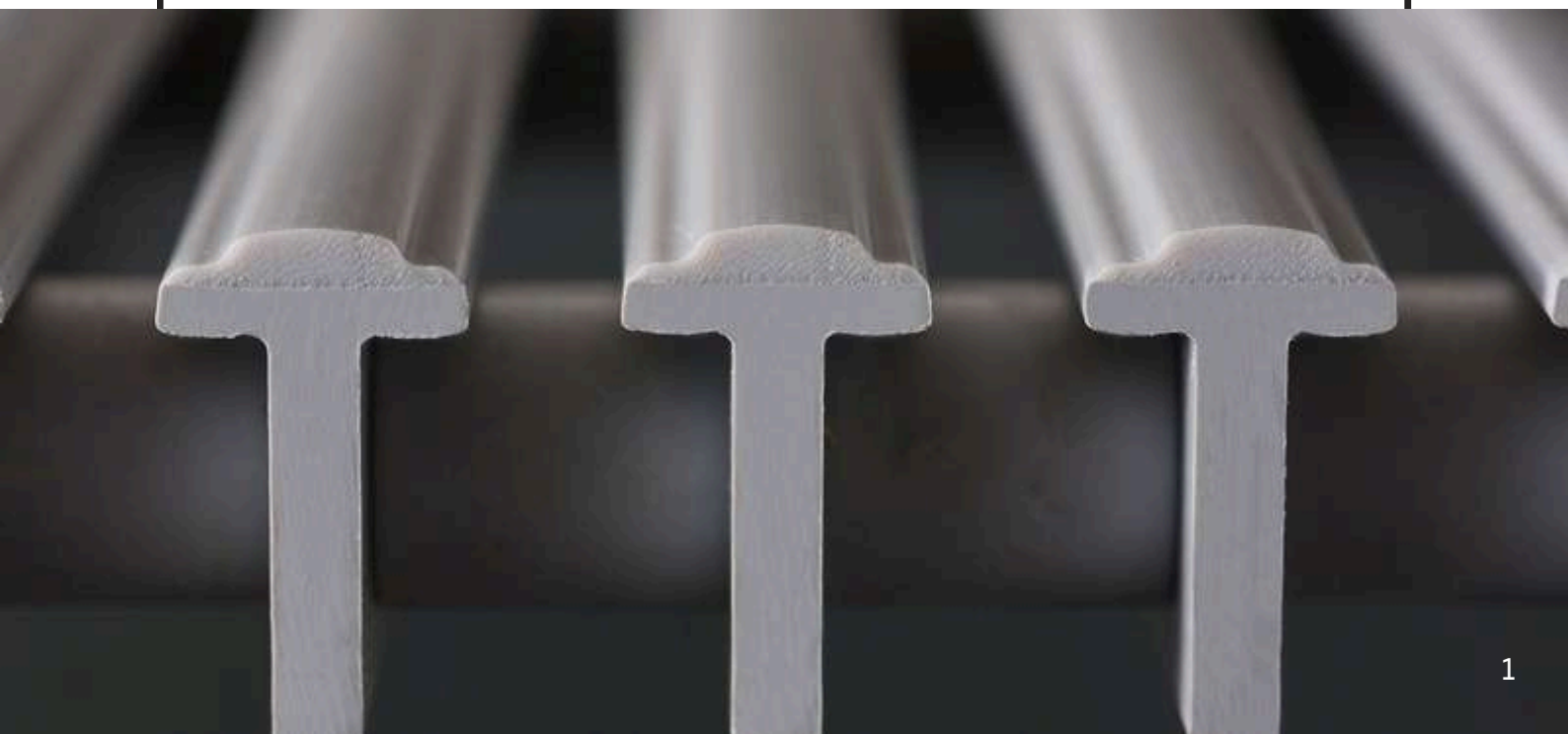



# Product Line Up

Our grating products are offered in a wide variety of shapes, sizes, and materials, providing a range of features to meet diverse project needs. While our offerings are diverse, our dedication to quality and efficiency in our grating solutions remains steadfast, guaranteeing durability that exceeds initial projections.

Within the realm of building materials, our product range encompasses a diverse selection of indoor and outdoor grates along with a variety of accompanying accessories. This breadth of offerings positions us as a leading and top-tier provider capable of meeting your precise project needs in this sector.

Our main product offerings will include indoor grating, outdoor grating, handrails, and accessories.



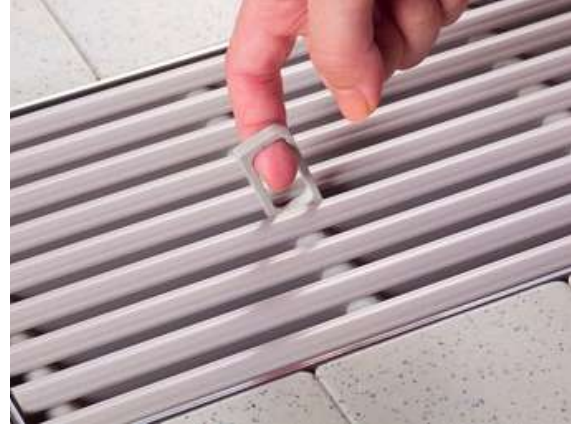

# SUGRA



SUGRA is a high-end PVC grating designed for indoor use. With a reliable history spanning more than twenty years, this product guarantees exceptional durability. Setting itself apart from traditional stainless steel gratings known for gaps and sharp edges, Sugra features a modern and seamless design. With a selection of seven colors, it seamlessly integrates with diverse home aesthetics, elevating the visual charm of balconies and back porches with a contemporary yet subtle touch.



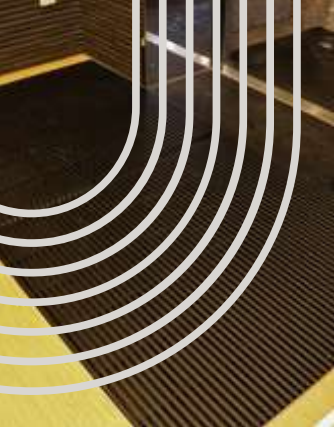

# Features

**Anti - Skid** : Made with soft PVC, the top surface offers both comfort and safety, preventing slips even when wet.

**Antibacterial** : Our products are JIS Z 2801-certified, guaranteeing proven antimicrobial protection for peace of mind.

**Antifungal** : SUGRA material is JIS Z 2911-certified for superior fungus resistance, offering reliable performance in humid or damp environments.

**Easy Maintenance** : Sugra's lightweight build and smooth surface let you simply rinse it with water and detergent for effortless cleaning, saving you time and effort.



# Colours



Beige , Light Grey , White , Pink , Dark Grey , Brown and Black



# Materials

Item	Material	Finish	Remarks
Mainbar	Hard/soft vinyl chloride (P.V.C)	-	Weather resistant formulation + antibacterial and antifungal specifications
Spacer	Hard vinyl chloride (P.V.C)	-	-
Remover	Hard vinyl chloride (P.V.C)	-	-
Crossbar	Stainless	-	-
Nut	Stainless	-	M4
Washer	Stainless	-	-

# SUGRA TEST

This section presents our product test reports, offering essential insights to facilitate informed decision-making. Alongside comprehensive descriptions and specifications, we provide the contents of product test reports for your convenience. This transparency enables thorough comparisons of features, performance, and overall value.



Test Item	Contents of Test	Evaluation
Load Bearing Test	Concentrated load is applied to one point with the wheel equivalent area of one wheelchair ( $\phi 50$ cylinder iron mass). (Local loading test based on JIS A 1450)	Confirm that there is no significant deflection residual deformation within the load capacity of the specification list
Weather resistance accelerated exposure test	Sunshine weather meter 63°C x 200hr rainfall time 12min/hr	No significant fading or discoloration
Chemical resistance test	Apply alkaline, neutral, and acidic once a day for 14 days	No abnormality in appearance
Hot water resistance test	Immerse at 60°C for 7 days	No discoloration or deformation
Impact resistance test	A steel ball with a diameter of 40 mm and weighing 1.3 kg is dropped from a height of 1 m.	No cracks or damage
Heat resistance test	70°C x 72hr, leaving time 2hr	No abnormality in appearance
Humidity test	40°C, humidity 95% x 24 hours	No abnormality in appearance
Hot water resistance test	87°C x 48 hours	No disturbing change in weight or discoloration of appearance
Heat/cool cycle test	-15°C (30 minutes) $\Leftrightarrow$ normal temperature (20°C 3 minutes) $\Leftrightarrow$ 70°C (30 minutes) = 1 cycle, 25 cycles, time left at normal temperature: 2 hours	No abnormality in appearance
Antibacterial test	JIS Z 2801	Antibacterial activity value 2.0 or more
Mold resistance test	Conducted according to JIS Z 2911 (mold resistance test method)	did not exceed 25% of the total area of the sample

# Product Specification



## GRS Series

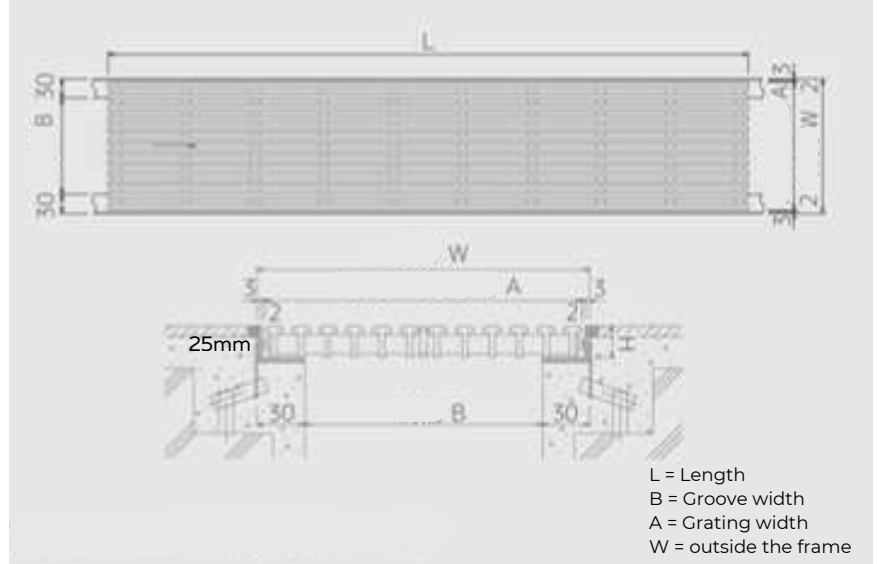

Height (H)	Grove Width (B)	Product Code	Colour	Grating Width (A)	Length (L)	Weight	Load Bearing
20	100	GRS-20W150	( Beige ) ( Light Grey ) ( White ) ( Pink ) ( Dark Grey ) ( Brown ) ( Black )	150	999	1.8kg	1.5kN
	150	GRS-20W200		200		2.4kg	1.0kN
	200	GRS-20W250		250		3.0kg	
	250	GRS-20W300		300		3.6kg	
25	100	GRS-25W150		150	999	2.0kg	
	150	GRS-25W200		200		2.7kg	1.5kN
	200	GRS-25W250		250		3.3kg	
	250	GRS-25W300		300		4.0kg	

## GRSK Series Reinforcement type

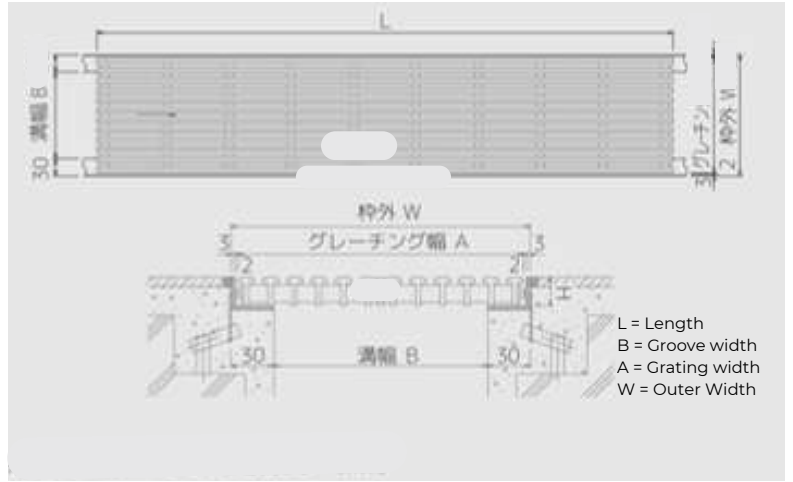

Height (H)	Groove Width (B)	Product Code	Colour	Grating Width (A)	Length (L)	Weight	Withstanding Load
20	100	GRSK-20W150	( Beige ) ( Light Grey ) ( White ) ( Pink ) ( Dark Grey ) ( Brown ) ( Black )	150	999	2.3kg	2.0kN
	150	GRSK-20W200		200		3.1kg	
	200	GRSK-20W250		250		3.9kg	
	250	GRSK-20W300		300		4.7kg	1.5kN
	300	GRSK-20W350		350		5.5kg	1.0kN
25	100	GRSK-25W150		150	999	2.5kg	2.0kN
	150	GRSK-25W200		200		3.4kg	
	200	GRSK-25W250		250		4.2kg	
	250	GRSK-25W300		300		5.1kg	
	300	GRSK-25W350		350		6.0kg	1.5kN
	350	GRSK-25W400		401		6.8kg	1.0kN

## GRSS Series

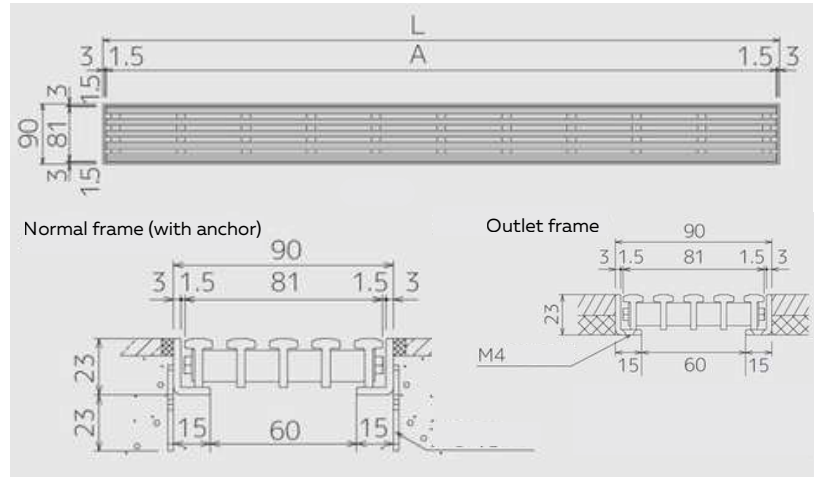
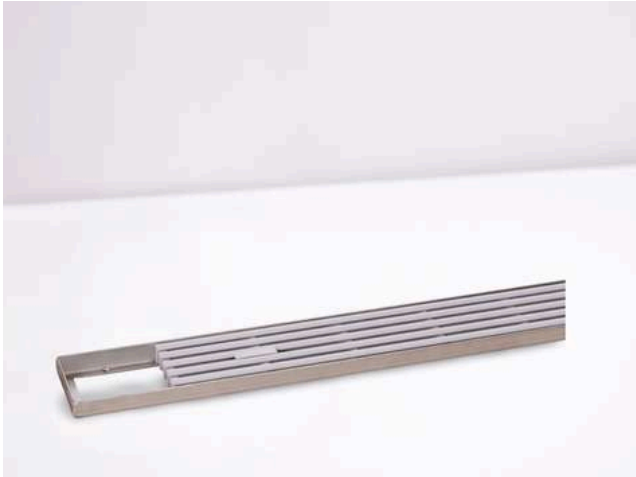

Product Code	Colour	Length (A)	Frame Length (L)	Width	Height	Weight
GRSS-20L600	( Beige ) ( Light Grey ) ( White ) ( Pink ) ( Dark Grey ) ( Brown ) ( Black )	585	594	81	20	0.5kg
GRSS-20L900		885	894			0.8kg
GRSS-20L1200		1185	1194			1.0kg
GRSS-20L1800		892 x 2	1794			1.7kg
GRSS-20L2000		992 x 2	1994			1.9kg

\*\*Withstanding Load for GRSS for all width size is : 2.0 kN

## GRSJ Series

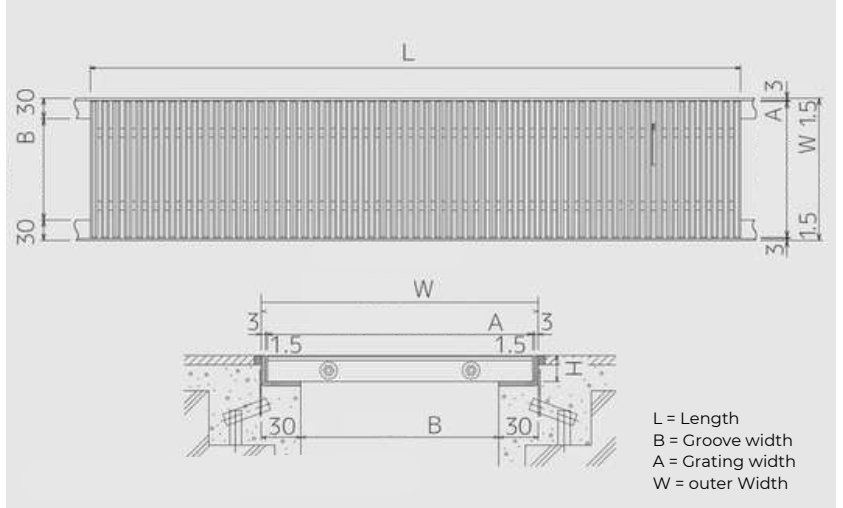

Height (H)	Grove Width (B)	Product Code	Colour	Grating Width (A)	Length (L)	Weight	Load
20	100	GRSJ-20W151	( Beige ) ( Light Grey ) ( White ) ( Pink ) ( Dark Grey ) ( Brown ) ( Black )	151	999	1.6kg	1.0kN
	150	GRSJ-20W201		201		2.2kg	
	200	GRSJ-20W251		251		2.7kg	
25	100	GRSJ-25W151		151	999	1.9kg	1.5kN
	150	GRSJ-25W201		201		2.5kg	1.0kN
	200	GRSJ-25W251		251		3.1kg	
	250	GRSJ-25W301		301		3.7kg	

## GRS - K Series

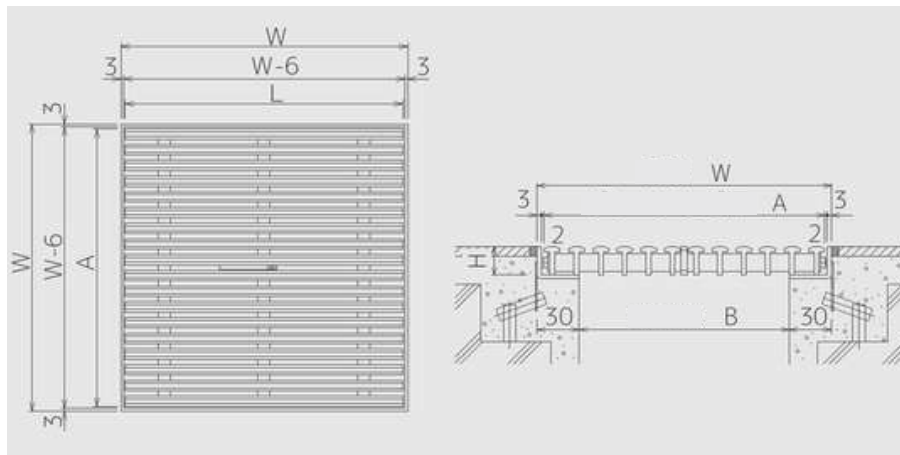

Height (H)	Groove Width (B)	Product Code	Colour	Grating Width (A)	Length (L)	Weight	Load Bearing
20	100	GRS-20K150	( Beige ) ( Light Grey ) ( White ) ( Pink ) ( Dark Grey ) ( Brown ) ( Black )	150	150	0.3kg	2.0kN
	150	GRS-20K200		200	200	0.5kg	
	200	GRS-20K250		250	250	0.8kg	1.5kN
	250	GRS-20K300		300	300	1.1kg	
	300	GRS-20K350		350	350	1.4kg	
25	100	GRS-25K150		150	150	0.3kg	2.0kN
	150	GRS-25K200		200	200	0.5kg	2.0kN
	200	GRS-25K250		250	250	0.8kg	
	250	GRS-25K300		300	300	1.3kg	
	300	GRS-25K350		350	350	1.7kg	
	350	GRS-25K400		401	400	2.3kg	1.0kN
	400	GRS-25K450		448	450	2.8kg	

## GRSK - K Series Reinforcement type



Height (H)	Grove Width (B)	Product Code	Colour	Grating Width (A)	Length (L)	Weight	Load Bearing
20	150	GRSK-20K200	( Beige ) ( Light Grey ) ( White ) ( Pink ) ( Dark Grey ) ( Brown ) ( Black )	200	200	0.5kg	2.0kN
	200	GRSK-20K250		250	250	0.9kg	
	250	GRSK-20K300		300	300	1.3kg	1.5kN
	300	GRSK-20K350		350	350	1.7kg	1.0kN
	350	GRSK-20K400		401	400	2.3kg	
25	150	GRSK-25K200		200	200	0.6kg	2.0kN
	200	GRSK-25K250		250	250	1.0kg	
	250	GRSK-25K300		300	300	1.4kg	
	300	GRSK-25K350		350	350	1.9kg	1.5kN
	350	GRSK-25K400		401	400	2.5kg	
	400	GRSK-25K450	448	450	3.0kg	1.0kN	
	450	GRSK-25K500	500	500	3.9kg		

## GRZ Series

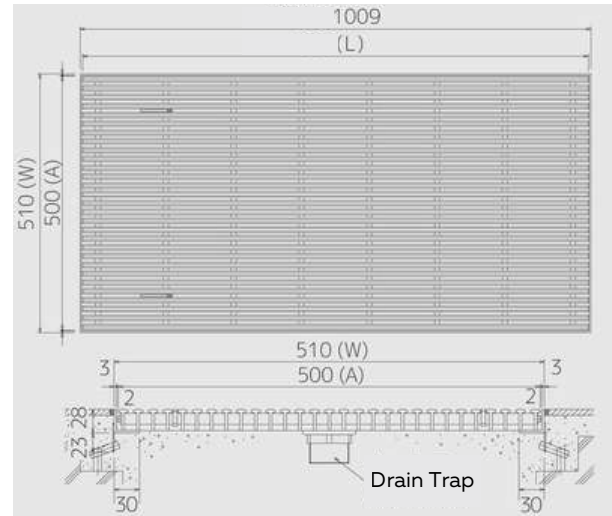
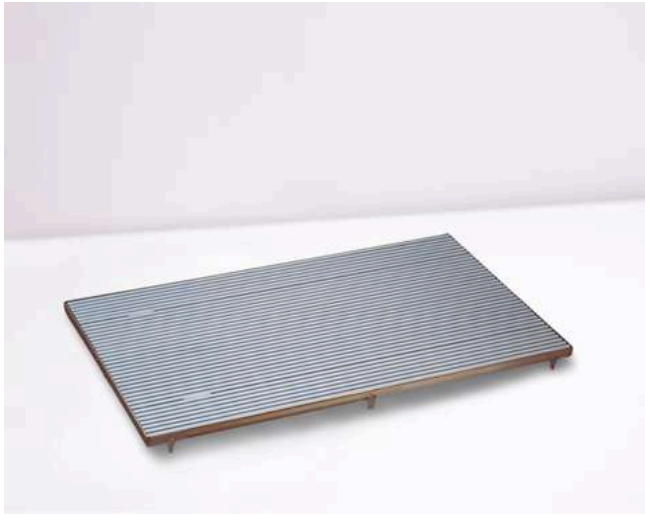

Product Code	Colour	Width (A)	Height (H)	Length (L)	Load
GRZ-25W500	( Beige ) ( Light Grey ) ( White ) ( Pink ) ( Dark Grey ) ( Brown ) ( Black )	500	25	999	5.2kg

\*Only for direct installation, so cannot be used as a trench cover.

\*Only available in height 25mm .

SUGRA is intended for direct installation, so the laying surface should be flat and free from lifting due to steps. If a water gradient is to be provided, it should be 2 mm deep at the lowest point from the installation slab surface.

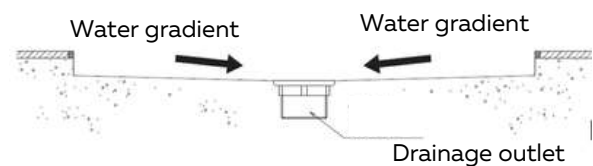

When cutting a drainage trench in the installation surface, make sure that the main bar does not get stuck in the trench. \*Around the muscle cut (2-3 mm)

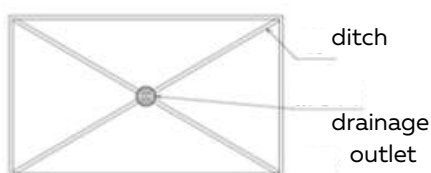

○ If the groove is cut at an angle, the groove width can be widened by up to 10 mm.

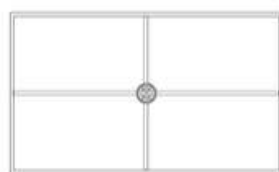

△ If the groove is cut at rightangles, about a muscle cut (2-3 mm).

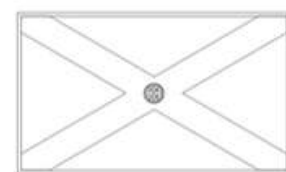

✗ If the trench is wide, the grating will be deformed by the steps.

$\theta=90^\circ$  (perpendicular)

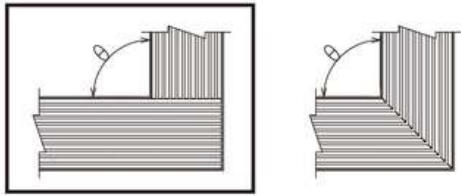

Engagement of grating bends  
For  $\theta=90^\circ$  (perpendicular), basics in bold unless otherwise indicated engage in a pattern.

$45^\circ \leq \theta < 90^\circ$  (acute angle)

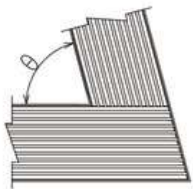

If the angle ( $\theta$ ) is between  $45^\circ$  and less than  $180^\circ$ , it is possible to cut diagonally according to each angle, as shown in the diagram on the right. However, there will be an additional charge.

$90^\circ < \theta \leq 135^\circ$  (obtuse angle)

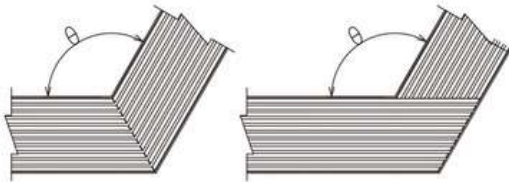

**Supports up to W = 300 with the above allocation.**

- \* Receiving frame supports up to  $\theta=60^\circ$ .
- \* If you want to use vertical type gratings please contact us regarding this matter.

$135^\circ < \theta < 180^\circ$  (most obtuse angle)

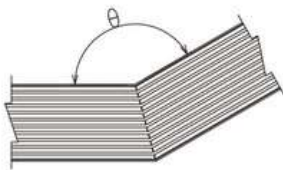

Multiple gratings can be secured together with a single nut.



- Vertical Type gratings and Slim type gratings cannot use this option.
- For the prices please contact us.
- By fixing the grating and receiving frame, the lid is prevented from bouncing up or rattling.
- The fixing bracket and grating are at the same height, with no difference in level, and the structure is completely flat.

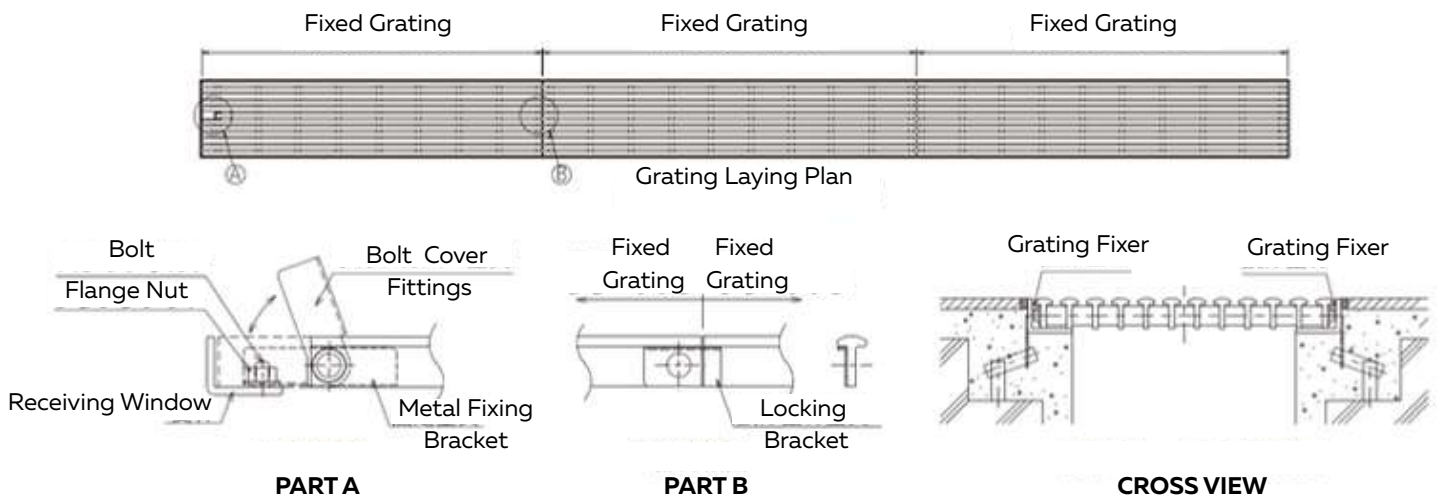

① Slide the standard grating into the frame.  
(The nut will catch on the retaining mechanism.)



② Place the fixed grating into the frame.



③ Secure with flange nuts.  
(The entire grating is secured in place.)

## OPTION ► Custom Parts

### Horizontal Type

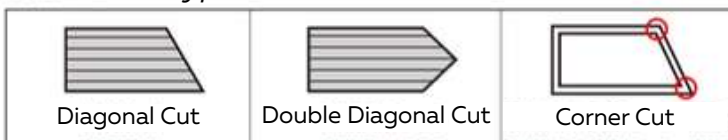

### Vertical Type

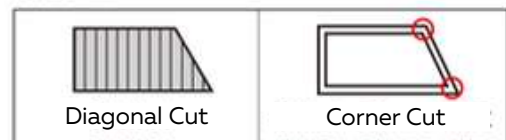

# SPECIAL POINTS

## **Requests at the time of installation**

- Do not place or hang hot objects on or around the grating. Doing so may deform the grating.
- When handling the product, do not subject it to impact or drop heavy objects on it. Doing so may deform the product.
- The curing tape attached to the product is for preventing scratches and stains. Please use it to protect the product until the installation is completed.

In high-temperature environments such as outdoors during the summer, the curing tape may cause the product to deform due to heat buildup. Please store the product indoors or in the shade where it will not be exposed to high temperatures until it is laid, and remove the curing tape as soon as possible after unpacking and laying the product.

- Be sure to place the grating in a stable position on the floor during both installation and cleaning. Propping it against a wall may cause it to fall over, resulting in injury, and deflection due to its own weight may cause the product to warp.

## **Cautions for use**

- Do not drop heavy objects. Doing so may deform the product.
- Do not change the direction of wheelchairs or stretchers on the grating. The grating may be damaged due to torsional load.
- Do not jump on the grating. There is a possibility of deformation.
- Do not apply strong acidic, alkaline, or other chemicals.
- Do not pour boiling water or place hot objects on it. Doing so may deform the top lid.
- If hair dye or other substances adhere to the hair, wipe them off immediately. If left unattended, the color may not be removed.
- Sledding may occur if the product is propped up against a wall or placed at an angle for an extended period of time. Be sure to store the product in a stable condition on a flat surface.

## **Maintenance**

- When removing the grating, lift it up with the removal tool.
- For daily care, wash the product with a mild detergent on a sponge. (Rinse with a mild detergent so that no detergent residue remains.)
- Do not use acidic or alkaline detergents or cleansers as they will damage the grating.
- After cleaning, check to see if any nuts or removal fixtures have been removed from the connecting parts.
- When cleaning the grating, be sure to place it on the floor in a stable position. Propping it against a wall may cause it to fall over, resulting in injury, and deflection due to its own weight may cause the product to warp.
- Make sure you will check the grating surface frequently.

# Reference

A New Value for PVC Gratings





# FORTE



FORTE is composed of Polyamide (PA6) reinforced with glass fibers, tailored for applications in high-traffic outdoor environments. PA6 boasts exceptional mechanical strength, rigidity, and impact resistance over diverse temperature ranges. The incorporation of glass fibers notably enhances the material's strength, stiffness, heat distortion resistance, abrasion resistance, and structural integrity.





# Features

**Strength** : FORTE is made of Polyamide (PA6) + Glass fiber, which significantly enhances its strength and durability.

**Diverse Application** : Highly weather-resistant and suitable for diverse outdoor environments. It also provides excellent non-slip performance, ensuring safety even when wet or exposed to oil.

**Load Resistance**: FORTE has a high load-bearing capacity, capable of supporting heavy loads without structural failure.

**Easy Maintenance** : SUGRA's lightweight build and smooth surface let you simply rinse it with water and detergent for effortless cleaning, saving you time and effort.



# Colours



Black , Beige , Brown , Light Grey , Dark Grey



# Materials

Item	Material	Finish	Remarks
Mainbar	Polyamide (PA6) + Glass fiber	-	-
Spacer	Hard acrylic (PMMA)	-	-
Crossbar	Stainless	-	-
Nut	Stainless	-	M4
Washer	Stainless	-	-

# FORTE TESTS

This section presents our product test reports, providing essential information to facilitate informed decision-making. Alongside comprehensive descriptions and specifications, the contents of the product test reports have been incorporated for your convenience. This transparency enables a thorough comparison of features, performance, and overall value.



Test Item	Contents of Test	Evaluation
Load bearing test	Concentrated load is applied to one point with the wheel equivalent area of one wheelchair ( $\phi 50$ cylinder iron mass). (Local loading test based on JIS A 1450)	Confirm that there is no significant deflection residual deformation within the load capacity of the specification list
Weather resistance accelerated exposure test	Sunshine weather meter 63°C x 200hr rainfall time 12min/hr	No significant fading or discoloration
Chemical resistance test	Apply alkaline, neutral, and acidic once a day for 14 days	Slight cracking was observed when acidic chemicals were applied. No abnormalities in appearance when neutral or alkaline chemicals were applied. * Acidic chemicals cannot be used.
Thermal water resistance test	Immersion at 60°C x 7 days	No discoloration or deformation
Impact resistance test	Steel ball of 40mm diameter and 1.3kg dropped from 1m height	No cracks or damage
Heat resistance test	70°C x 72hr, leaving time 2hr	No abnormality in appearance
Moisture resistance test	40°C, 95% humidity x 24hr	No abnormality in appearance
Hot water resistance test	100°C x 48hr	No adverse weight change or appearance discoloration
C.S.R measurement test (Coefficient of Slip Resistance)	In accordance with JIS1454 17 Slipperiness test, Measured under dry, wet and oil-applied conditions	C.S.R=0.4 or more *3 Dry: 0.78 Wet: 0.67 Oil-applied condition: 0.65 (measured value)*4
Mold resistance test	Conducted according to JIS Z 2911 (mould resistance test method)	Did not exceed 25% of the total area of the sample
Heat and cold cycle test no abnormalities in appearance	-15°C (30 min) $\Leftrightarrow$ room temperature (20°C, 3 min) $\Leftrightarrow$ 70°C (30 min) = 1 cycle, 25 cycles, time at room temperature: 2hr.	No abnormalities in appearance



# Product Specification



## GNN Series

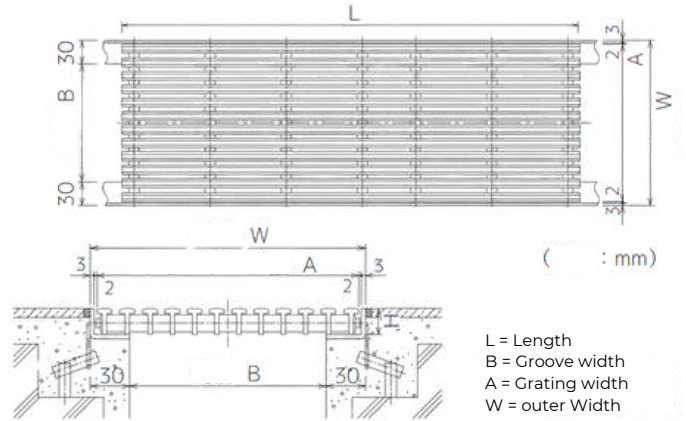

Grove Width (B)	Product Code	Colour	Grating Width (A)	Height (H)	Length (L)	Weight	Load Bearing	Outer Width (W)
100	GNN-20W150	( Beige ) ( Light Grey ) ( Brown ) ( Dark Grey ) ( Black )	150	20	999	1.9kg	2.5kN	160
150	GNN-20W200		200			2.5kg	2.5kN	210
200	GNN-25W250		250			3.1kg	2.0kN	260
250	GNN-20W300		300			3.7kg	1.5kN	310

The minimum and maximum grating lengths are 150 mm and 1,305 mm, respectively.

\*custom made products can also be manufactured. Please contact us when ordering.

When ordering only grating other than the above standard width dimensions, please inform us of the dimensions inside the frame (Inner Width). However, in some cases we may not be able to manufacture to your requested dimensions.

Please contact us for the price of special-order products, diagonal processing, fixed specifications, and allocation specifications other than the standard.

### GNNJ Series

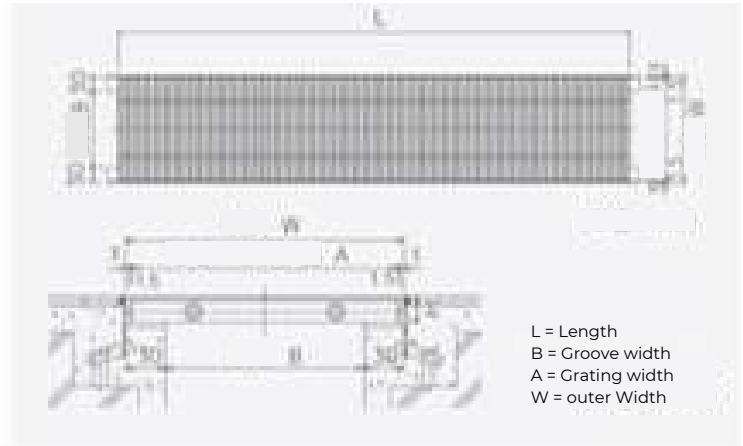

L = Length  
B = Groove width  
A = Grating width  
W = outer Width

Height (H)	Grove (W)	Product Code	Colour	Width (A)	Length (L)	Weight	Load
20	100	GNNJ-20W151	( Beige ) ( Light Grey ) ( Brown ) ( Dark Grey ) ( Black )	151	999	1.7kg	7.0kN
	150	GNNJ-20W201		201		2.3kg	4.5kN
	200	GNNJ-20W251		251		2.8kg	3.5kN
	250	GNNJ-25W301		301		3.2kg	3.5kN
	300	GNNJ-25W351		351		3.9kg	2.0kN

Note when ordering: Please inquire separately for the delivery date for colors other than black.

The maximum production length of a single grating is 999mm.

\*Diagonal processing and fixed specifications for grating can also be manufactured.

Please contact us when ordering.

\*Please contact us with the dimensions inside the frame (Inner width) when ordering only grating other than the above standard width dimensions.

However, in some cases we may not be able to manufacture to your requested dimensions.

If W=117mm or less, then the price will be increase.

Please contact us for for special pricing for custom made orders.

## GNNS Series

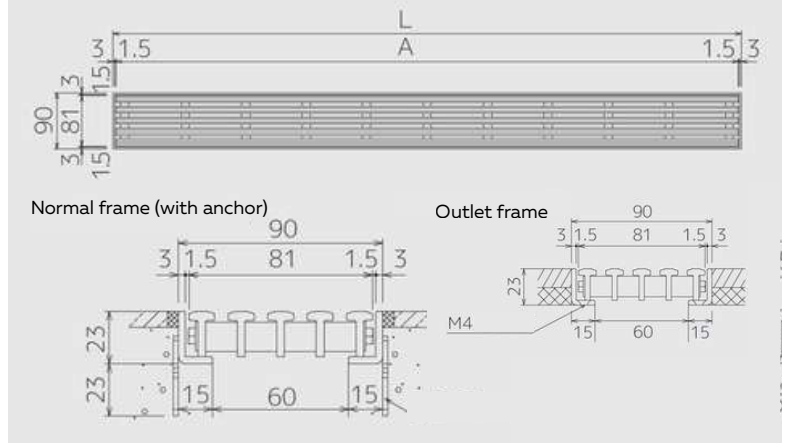
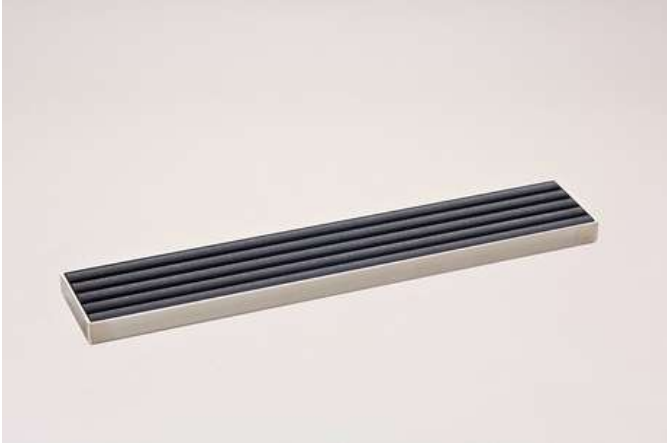

Height (H)	Product Code	Colour	Grating Length (A)	Frame Length (L)	Width	Weight	Load
20	GNNS-20L600	( Beige ) ( Light Grey ) ( Brown ) ( Dark Grey ) ( Black )	585	594	81	0.6kg	2.0kN
	GNNS-20L900		885	894		0.9kg	
	GNNS-20L1200		1185	1194		1.1kg	
	GNNS-20L1800		892x2	1794		1.8kg	
	GNNS-20L2000		992x2	1994		2.0kg	

Note when ordering: Please inquire separately for the delivery date for colors other than black.

\*Special order products of different lengths are available.

\*Please contact us for the price of special-order products of different lengths and allocation specifications.

## GNN-K Series

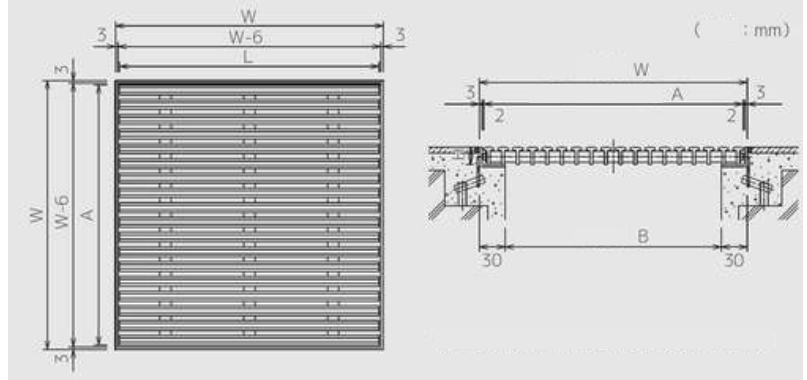

Height	Product Code	Colour	Grating		Outer Width (W)	Weight (Gratings)	Load Resistance Concentrated	Load Resistance Equally
			A	L				
20	GNN-20K150	( Beige ) ( Light Grey ) ( Brown ) ( Dark Grey ) ( Black )	150	150	160	0.4kg	7.0kN	5.0kN/m <sup>2</sup>
	GNN-20K200		200	200	210	0.6kg	6.0kN	
	GNN-20K250		250	250	260	0.9kg	4.5kN	
	GNN-20K300		300	300	310	1.2kg	3.5kN	
	GNN-20K350		350	350	360	1.8kg	3.0kN	
	GNN-20K400		401	400	410	2.0kg	2.0kN	
	GNN-20K450		448	450	460	2.5kg	1.5kN	

Note when ordering: Please inquire separately for the delivery date for colors other than black.

\*Special order products of different lengths are available.

\*Please contact us for the price of special-order products of different lengths and allocation specifications.

# Colours



- Grating Lid : Black , Beige , Brown , Light Grey , Dark Grey
- Drainage unit colors that you can match with FORTE grating lid colors.

# FORTE Corner Customization

$\theta=90^\circ$  (perpendicular)

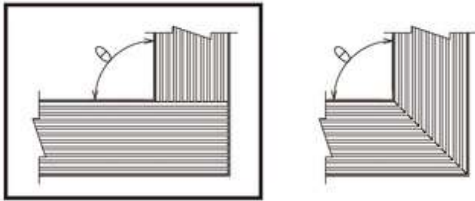

Engagement of grating bends  
For  $\theta=90^\circ$  (perpendicular), basics in bold unless otherwise indicated engage in a pattern.

$45^\circ \leq \theta < 90^\circ$  (acute angle)

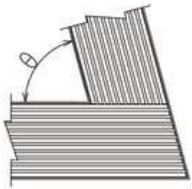

If the angle ( $\theta$ ) is between  $45^\circ$  and less than  $180^\circ$ , it is possible to cut diagonally according to each angle, as shown in the diagram on the right. However, there will be an additional charge.

**Supports up to W = 300 with the above allocation.**

$90^\circ < \theta \leq 135^\circ$  (obtuse angle)

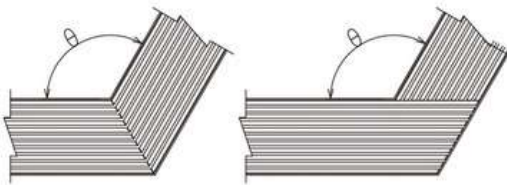

- \* Receiving frame supports up to  $\theta=60^\circ$ .
- \* Please contact us if you want to use the order type.

The grating is fixed to the frame with lockers placed at four locations.

$135^\circ < \theta < 180^\circ$  (most obtuse angle)

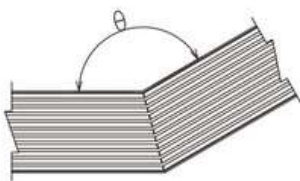

Lockers are not available for Vertical type and Slim type. Please contact us for price and delivery date.





## OPTION ► Fixed specification

The grating is fixed to the frame with special fixtures placed at four locations.

\*Fixed specifications are not available for the sequential eye type and slit type.

\*Please contact us for price and delivery date.

- Fixing the grating to the frame prevents the lid from bouncing or rattling.
- The fixing bracket and grating are at the same height, with no difference in level, and the structure is completely flat.
- The fixing section uses U nuts to prevent loosening of the bolts even when subjected to vibration or impact.

## OPTION ► Removal Tool

Forte Removal Tool

- Material: SUS304
- Can be removed by hooking onto the spacer between the main bars of the grating.



## OPTION ► Material Specifications

This specification prints stone and wood grain and special patterns to match the flooring material.



Three types (one wood-grain type and two stone-grain types)

# SPECIAL POINTS

## **Requests at the time of installation**

- Do not lay grating underwater at any time (diving) or lay it in a location where it will be in contact with water for a long period of time. The glass fibers will be exposed, and direct contact with the skin may cause a prickling sensation.
- The curing tape attached to the product is for preventing scratches and stains. Please use it to protect the product until the installation is completed.
- Do not place high-temperature objects on or around the grating. Doing so may deform the grating.
- When handling the grating, do not subject it to impact or drop heavy objects on it. Doing so may deform the product.
- If mortar or other material adheres to the surface, remove it immediately.
- The cast surface treatment on the surface provides non-slip properties. Please note that the unevenness of the surface is a specification.

## **Cautions for use**

- Do not use the product under loads exceeding the design conditions. There is a possibility of deformation or damage.
- Be sure to place the grating in a stable position on the floor during installation and cleaning. If it is placed against a wall, it may fall over and cause injury, or the product may warp due to deflection caused by its own weight.
- Do not change the direction of a wheelchair or stretcher on the grating. The grating may be damaged due to torsional load.
- Do not drop or splash heavy objects on the grating. Doing so may deform the grating.
- Do not place hot objects on the grating or keep it away from fire. The grating may deform or burn.
- Do not drag objects on the grating. The surface may be abraded and the glass fiber may be exposed.
- Do not apply strong acidic or alkaline chemicals. If chemicals adhere to the grating, rinse it off immediately under running water.

## **Maintenance**

- Do not use strong acid, strong alkali, or chlorine bleach cleaning agents (especially chemicals with a PH of less than 3), as they may damage the grating.
- When removing the grating, lift it up with a hook-shaped tool. (A removal tool is available as an option.)
- Please wash the grating with water for daily maintenance.
- After cleaning, check to make sure that the nuts and metal fittings of the connecting section have not been removed.



# Reference

A Strong and Stylish Grating

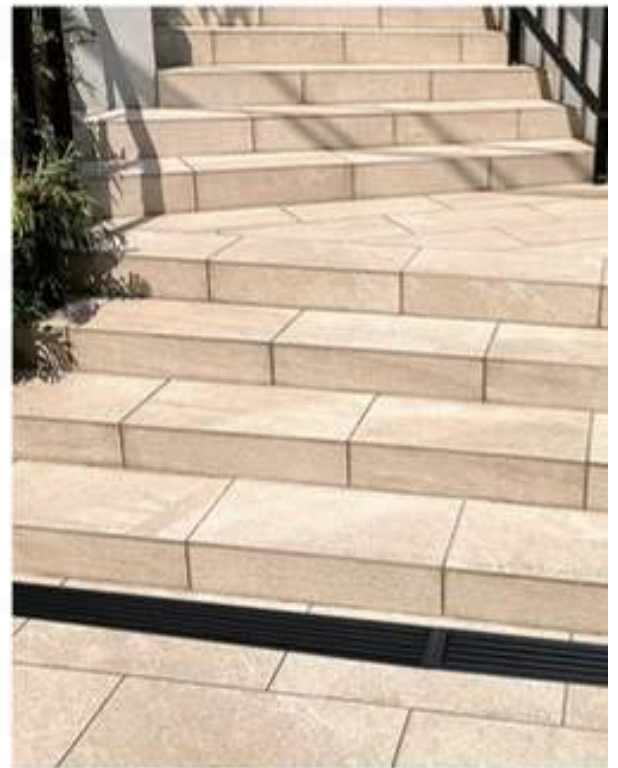
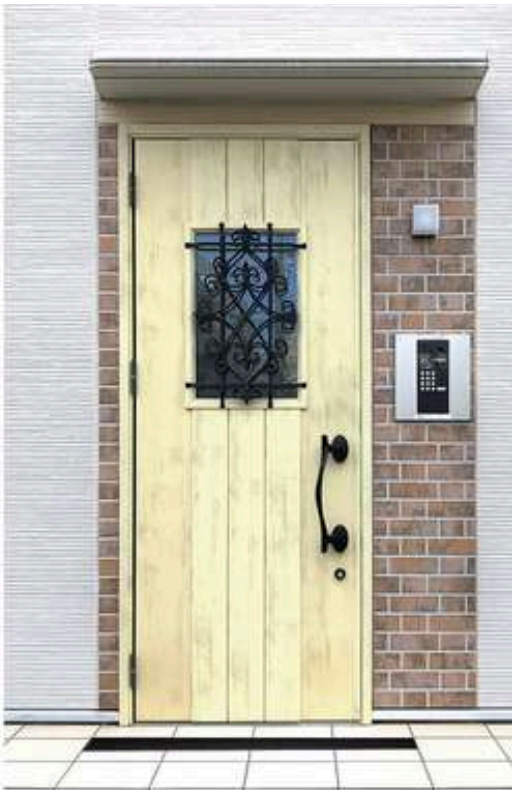
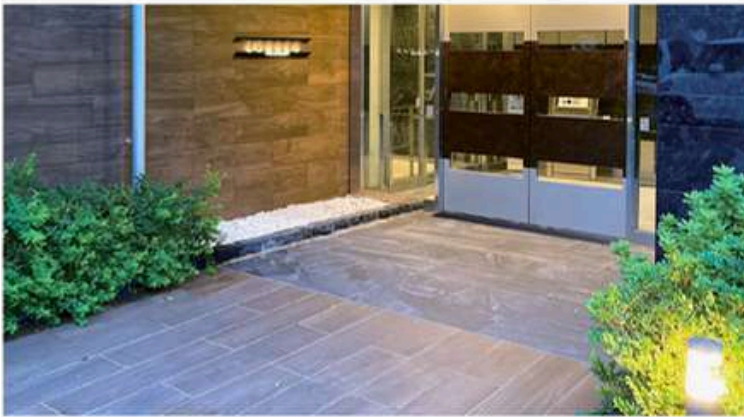



# FLEX



FLEX is an ideal grating solution for indoor and outdoor swimming pools. Crafted from resilient and flexible materials, it can be effortlessly shaped to accommodate any pool configuration, offering versatility in design. Moreover, its pliability simplifies maintenance, allowing for convenient rolling and unrolling when necessary.





# Features

**Anti-Skid** : To ensure safety on wet surfaces, Flex's top and bottom are made of soft acrylic material. This anti-skid surface makes it safe to walk on even with wet feet.

**Flexibility** : Flex is revolutionary for its ability to bend in both directions. With an innovative design, the Flex can be fitted into curved sections with ease.

**Easy Installation** : With Flex, the installation of a swimming pool grating has never been so easy and effortless. Flex comes in 1-meter lengths and is easily extended by connecting other gratings together.

**High Adapt & Conform** : Because of its flexible characteristics, it can fit into even the most difficult parts. Customisation at its best.



# Colours

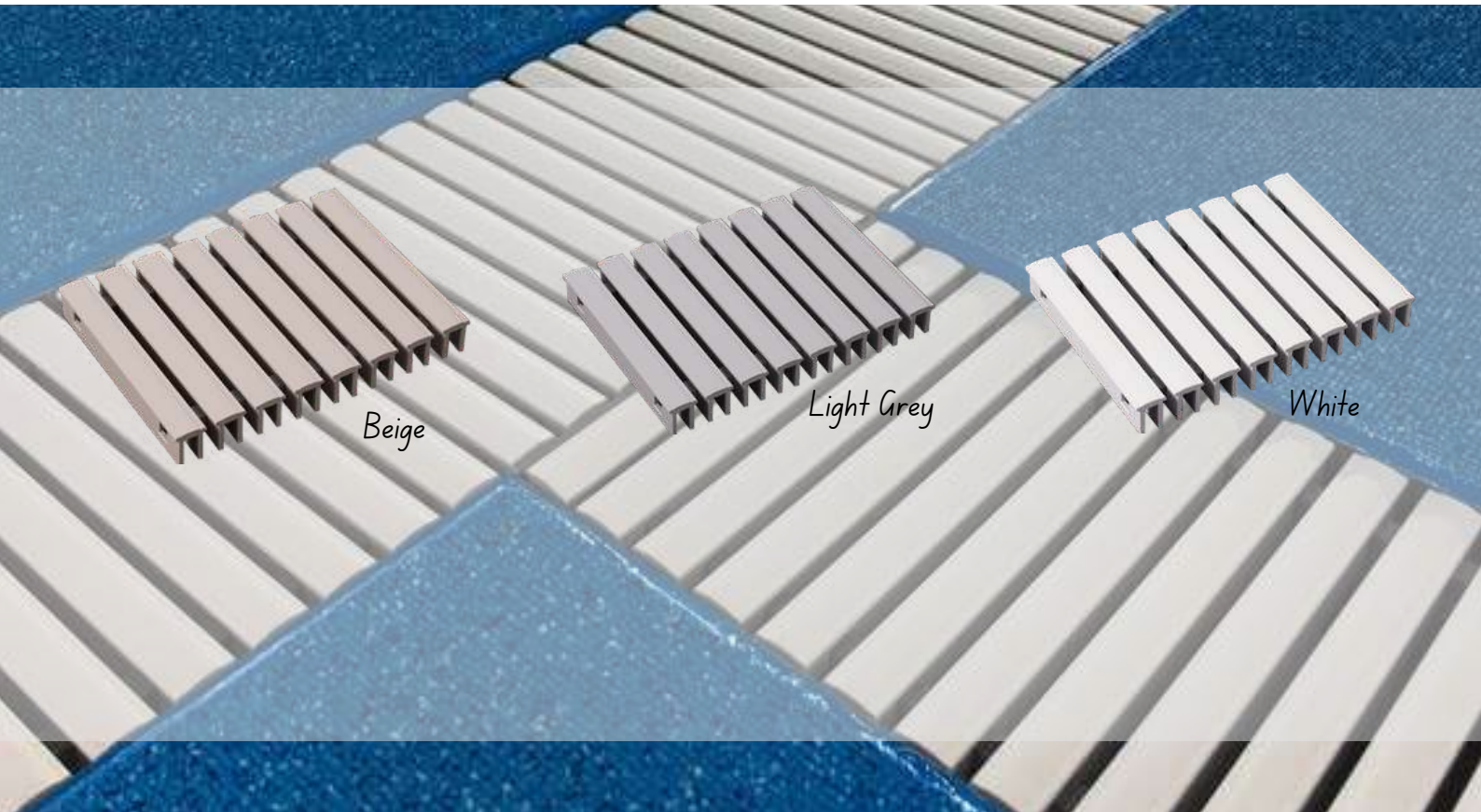

Beige , Light Grey , White



# Materials

Item	Material	remarks
Mainbar	Hard polyvinyl chloride (P.V.C.)/Soft acrylic	Weather-resistant formulation, colorless and transparent
Joint	Soft polyvinyl chloride (P.V.C.)	Anti-bacterial and anti-mold specifications
Spacer for Straight Line	Polypropylene (P.P.)	-
Quick Joint	Hard acrylic	-

# FLEX TEST

This section presents our product test reports, offering essential insights to enhance your decision-making process. Alongside comprehensive descriptions and specifications, we provide the contents of product test reports for your convenience. This transparency enables you to make informed comparisons regarding features, performance, and overall value.



Test Item	Contents of Test	Evaluation
Load Bearing Test	Concentrated load is applied to one point with the wheel equivalent area of one wheelchair ( $\phi 50$ cylinder iron mass). (Local loading test based on JIS A 1450)	Confirm that there is no significant deflection residual deformation within the load capacity of the specification list
Weather Resistance Accelerated Exposure Test	Sunshine weather meter 63°C x 200hr rainfall time 12min/hr	No significant fading or discoloration
Chemical Resistance Test	Alkaline, neutral and acidic applied once a day x 14 days	No abnormalities in appearance
C.S.R.B Measurement Test (Coefficient of Slip Resistance)	Coefficient of slip resistance in the case of bare feet, as measured by the slipperiness test for floor coverings specified in JIS A 1454.	C.S.R. = 0.7 or more Dry state: 0.93 Water-applied state: 0.88
Environmental Testing	Test specimen changes in ambient temperatures between -25°C and 60°C.	No cracks or damage.
Heat-Resistance Test	70°C x 72hr leaving time 2hr	No abnormalities in appearance
Hot Water Resistance Test	87°C x 48hr	No disturbing weight changes or discolouration of the external appearance
Thermal Cold Cycle Test	Minus 15 °C (30 min) $\leftrightarrow$ room temperature (20 °C, 3 min) $\leftrightarrow$ 70 °C (30 min) = 1 cycle, 25 cycles, time at room temperature: 2 hr.	Regardless of water conditions in gutters, No floating in each size
Buoyancy Test	A grating is placed on a platform that resembles a poolside gutter and 90 litres of water is poured through it at once.	No lifting of each size, regardless of the water conditions in the gutter

# Product Specification

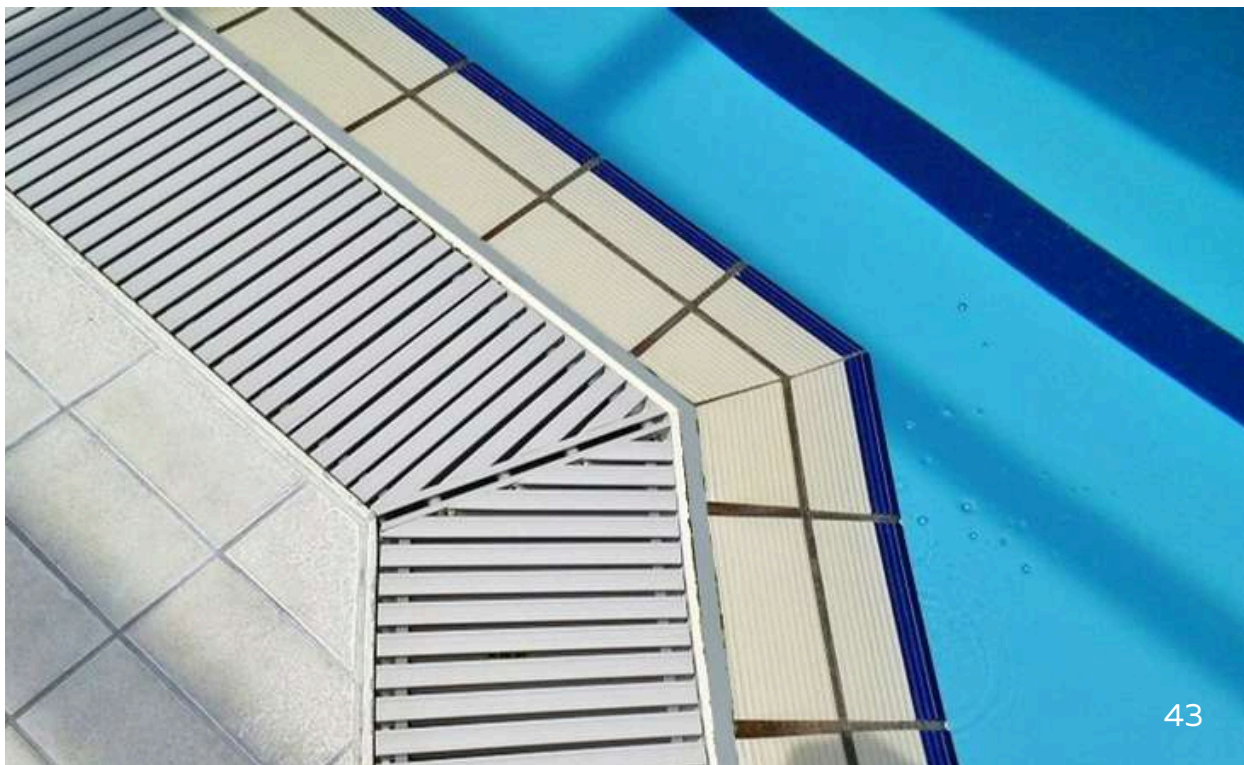

## GAP / GAPR Series

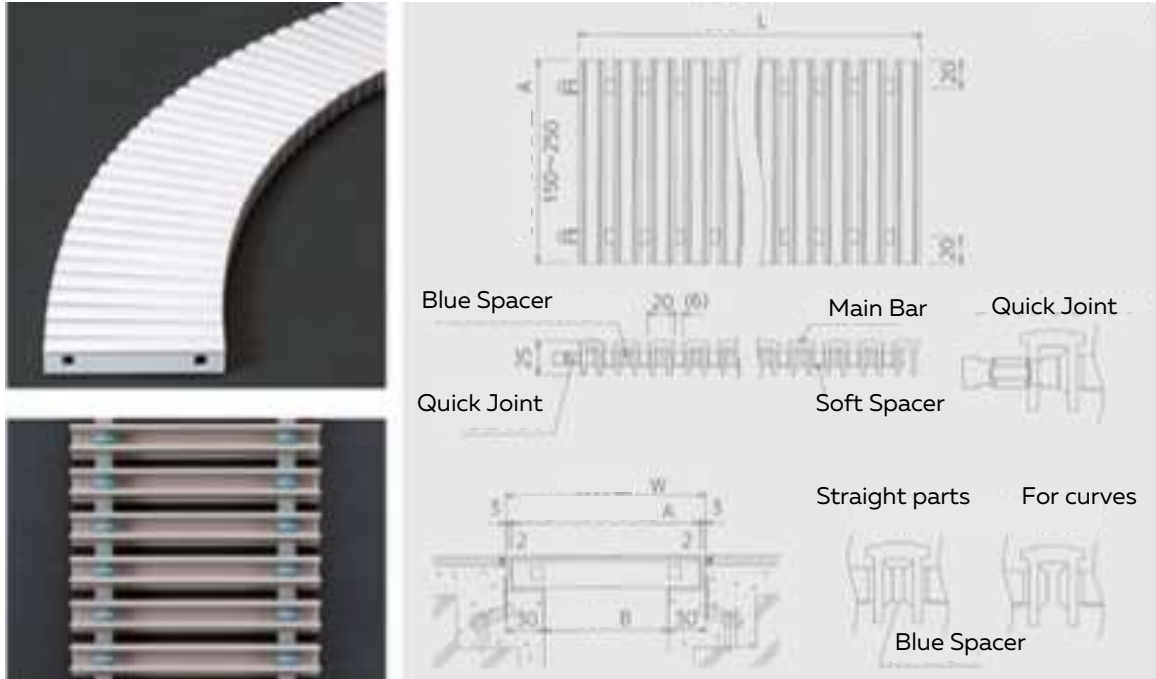

Grove Width	Code	Colour	Width A mm	Height	Length	Weight	Load Bearing	Outer Width
100	GAP-25W150	( Beige ) ( Light Grey ) ( White )	150	25	1000	1.9kg	2.0kN	160
150	GAP-25W200		200			2.4kg	1.5kN	210
200	GAP-25W250		250			3.0kg	1.0kN	260
250	GAP-25W300		300			3.6kg		310

Grove Width	Code	Colour	Width A mm	Height	Length	Weight	Load Bearing	Outer Width
100	GAPR-25W150	( Beige ) ( Light Grey ) ( White )	150	25	1000	1.9kg	2.0kN	160
150	GAPR-25W200		200			2.4kg	1.5kN	210
200	GAPR-25W250		250			3.0kg	1.0kN	260
250	GAPR-25W300		300			3.6kg		310

## GAP / GAPR Series



Grove Width	Code	Minimum Curve Inner
100	GAP-25W150	N/A
150	GAP-25W200	N/A
200	GAP-25W250	N/A
250	GAP-25W300	N/A

Grove width	Code	Minimum Curve Inner
100	GAPR-25W150	500
150	GAPR-25W200	750
200	GAPR-25W250	1000
250	GAPR-25W300	1250

# SPECIAL POINTS

## Quick Joint

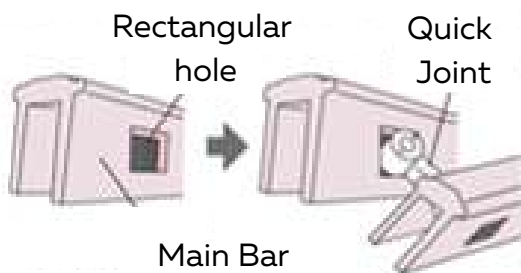

To connect, insert the quick joint on the end of the main bar straight into the square hole (Fig. 1)

Unlike other joints, the quick joint section prioritizes ease of connection, so it may come off if the main bar is bent too hard or pulled too hard. If the main bar is bent or pulled too hard, it may come off. If this happens, reinsert the main bar. In that case, reinsert it again.

## At the time of installation

- Make sure that there are no foreign objects or unevenness on the surface of the frame to be laid.
- For ease of cleaning, connect the length of the joints within 5m.
- Use GAP for straight lines and GAPR for curved lines. The GAPR for curves can be used freely for curves (see for the minimum R inside a curve in the price list on page 45), so follow the installation method.
- Quick joints" are only available at two locations at the tip.

## Identity

- To identify straight and curved grating, a blue spacer on the back side of the grating indicates straight grating and a blue spacer on the back side of the grating indicates curved grating.

## Installation

1. Both straight and curved lines can be adjusted from 995 to 1020 mm by the expansion/contraction function of the joints.
2. If extra length is required at the final end of laying, please remove the connecting joints or cut the joints with nippers, etc. for adjustment.
3. The main bar "1000mm or 500mm" is shipped as a single piece. Normally, insert the quick joint at the tip into the opening hole of the connecting side to connect.
4. When installing in an R (curved) frame, use your fingers to bellows the main bar that will be inside the R. This will narrow the interval and form an R.
5. For installation in a R (curved) section, connect the main bars to each other with a quick joint or a joint to the extent that it does not affect maintenance. Since the main bars are spread in a bellows style, there may be a large gap between main bars (Figure 1). (Fig. 1) Connect the ends according to "Connecting Joints" on the left.

# SPECIAL POINTS

## Maintenance

- When using a joint (soft) instead of a quick joint for length adjustment, etc., remove one main bar at the end to expose the joint tip and insert it into the square hole of the next main bar.
- Insert the joint umbrella not by pushing straight in, but by pushing the lower part of the joint umbrella slightly into the square hole and then lifting it up using the principle of leverage. (Figure 2)
- After pressing in, make sure that the joint bevel is open. If the umbrella is even partially closed, it may fall out. (Fig. 3)

\*It may be difficult to connect joints when the temperature is low, such as in winter. It is recommended to work in a place where the room temperature is as high as possible.

(Figure 1)

\*4, 5 Curves section only

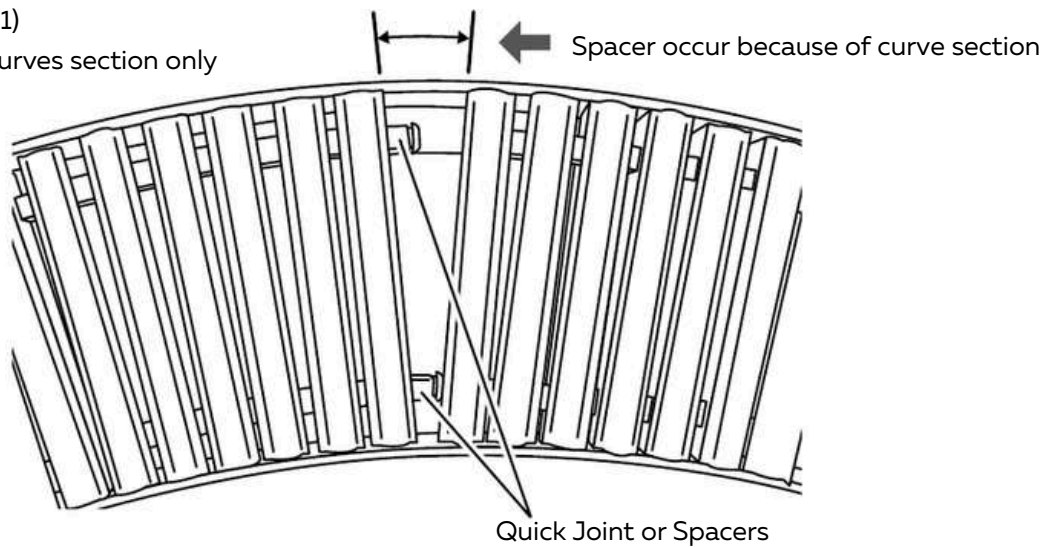

(Figure 2)

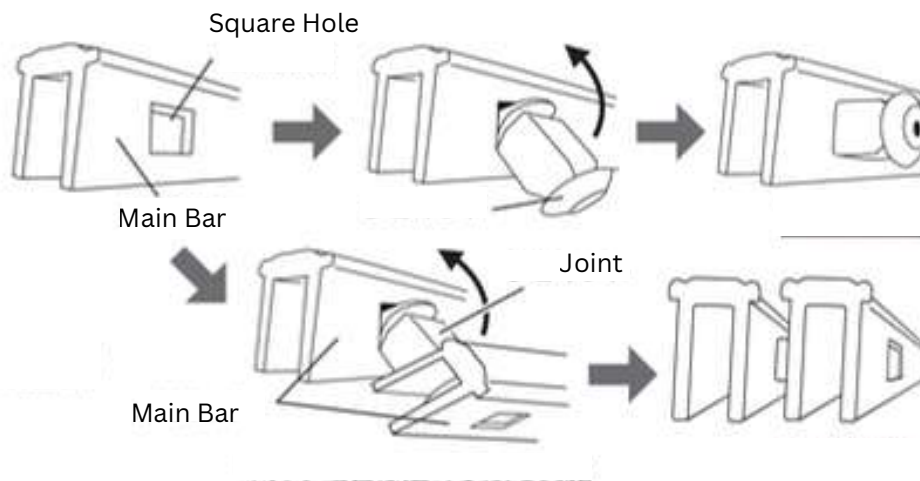

(Figure 3)

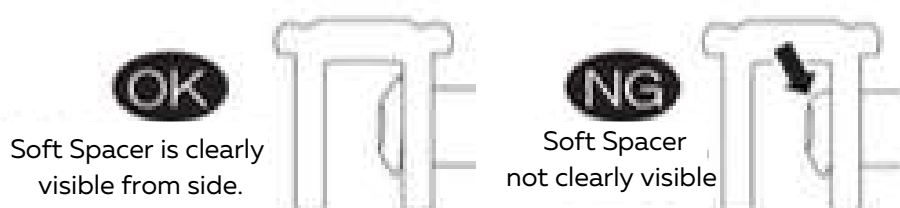

# Reference

Flexible Grating for indoor and outdoor pools

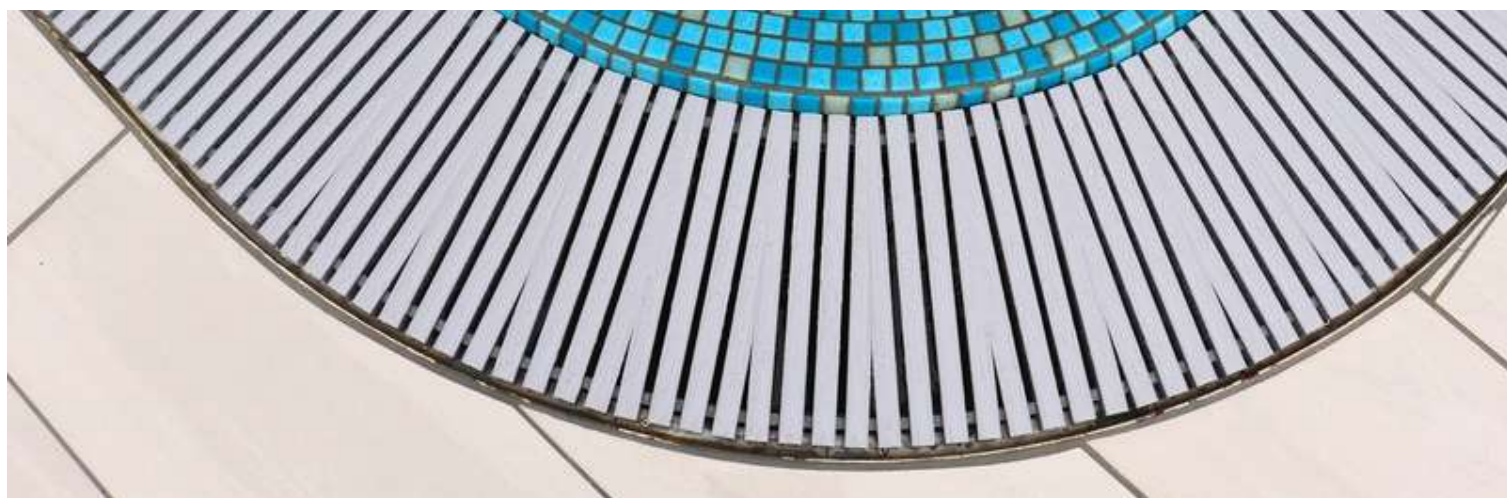

# DRIVEN BY INNOVATION

Since our inception, Shimabun has been dedicated to fostering creativity and pushing the boundaries of technology with a pioneering ethos. As a distinguished specialist in gratings, we have earned the trust of customers both locally and globally through our extensive expertise. Our commitment to customer satisfaction propels us to innovate, deliver exceptional products and services, and make meaningful contributions to society.

Central to our offerings are universal design products that prioritize safety, security, and user comfort. By actively engaging with our customers, we continuously refine our quality standards, enhance productivity, and advance our manufacturing processes to bolster our competitiveness in the market.

Our strategic objectives include elevating company worth through product refinement and expanding our sales network, both domestically and overseas. By collaborating with various stakeholders, we strive to boost corporate value and play a role in fostering a prosperous society. Through collaborative efforts, we are forging a future underpinned by innovation and unwavering customer satisfaction.

## Our Distributors



*Indonesia*

PT Austindo Perdana (Bali island)  
PT Sanwell Austindo (Jakarta)



*Singapore*

ILet Pte Ltd



*Thailand*

Rainbow Enterprise Marketing  
Group Co. LTD



*Philippines*

A & J MAJU MARKETING



*Malaysia*

Lentura Surfaces SDN BHD  
Agrow Corporation SDN BHD



*UAE*

OPUS Building Materials